

1985 BOMBARDIER CHALLENGER 601-1A | SN 3046



MACH  
.74



PASSENGERS  
9



RANGE (NM)  
3,871

CONTACT: NATE METZLER  
nate@soljets.com | +1.847.920.7000

# 1985 BOMBARDIER CHALLENGER 601-1A | SN 3046

**AIRCRAFT LISTING DETAILS:**

Total Hours: 6,195  
 Total Landings: 4,668

**ENGINES:** General Electric CF34-3A

	Left	Right
Total Hours:	17,981	17,987
Engine Cycles:	10,525	10,386
Hours Since Overhaul:	180	180

**APU:** Honeywell GTCP36-100(E)

Total Hours: 4,310

**AIRCRAFT HIGHLIGHTS:**

- \* ADS-B
- \* No Damage History
- \* Purchased and Installed -3A Engines Within Last 170 Hours - Freshly Overhauled by Lufthansa
- \* CAMP
- \* **Enrolled in JSSI Unscheduled**

**AVIONICS:**

- \* Honeywell EDZ-803 5-Tube and ProLine II Avionics Suite
- \* Honeywell SPZ-600 Autopilot
- \* Dual Universal UNS-1K with 12-Channel GPS
- \* Dual Collins ADF-60
- \* Dual Collins DME-42
- \* Dual Collins TDR-94D Mode S Transponders
- \* 406 MHz ELT
- \* Fairchild A100 CVR
- \* Fairchild F1000 FDR with 21-Parameters
- \* Dual Honeywell LASERNAV III
- \* Dual Honeywell LASEREF III
- \* Collins TCAS II 7.1 with Change
- \* Dual Honeywell AZ-810 Air Data Computers
- \* Certified Terrain Awareness and Warning System
- \* Dual Collins VHF-22B with 8.33 Spacing
- \* Dual King KHF-950 with SELCAL
- \* Dual Collins VIR-32 with FM Immunity
- \* Dual Collins ALT-55B
- \* Honeywell AA-300
- \* Sperry Primus 800 Color

## 1985 BOMBARDIER CHALLENGER 601-1A | SN 3046



### FEATURES / OPTIONS:

- Entertainment Center with Airshow 400, 30-inch LCD Video Monitor, LCD Monitors at Each Seat, DVD/CD Payer with Mid-Continent Controls, and iPod Docking Station
- Extended Range/Auxiliary Fuel
- Altitude Alert
- Glidescope Indicator
- Marker Beacon
- Gross Weight Increase Mod
- Brandon Extended Range Fuel Tanks
- Securaplane 5000 Security System
- MagnaStar C-2000 Phone

### INTERIOR:

2005 Refurbishment. Nine (9) Passenger Seating including Aeronappa Osprey Leather Forward Club, followed by Two (2) Leather Executive Seats Across a Kashmir Mustard Fabric Divan. The Cabin is Complete with High-Gloss Polished Finish Block Cut Bubinga Wood Veneer and an Aft Externally Serviceable Lav with Vanity. Galley is Equipped with Glassware Stowage, Ice Drawer, and Cabinet Storage.

### EXTERIOR:

2005 Refurbishment. Overall Matterhorn White Base Accented with Emerald Green Pearl and Desert Gold Accent Stripping.

# 1985 BOMBARDIER CHALLENGER 601-1A | SN 3046

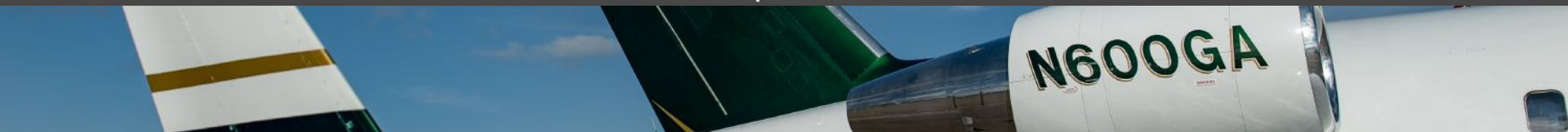

## MAXIMUM CRUISE SPEED

497 ktas    920 km/hr

## NBAA IFR RANGE

Maximum    3,871 nm    7,169 km

## CEILING

Maximum certified    41,000 ft    12,500 m

## RATES OF CLIMB

Single engine    1,048 ft/mi    319 m/m

## AIRSPEED LIMITS

Vmo    365 kias    676 km/hr

## APPROACH SPEED

Landing configuration (VREF)    134 kcas    248 km/hr

## PRESSURIZATION

Nominal pressure differential    8.8 psi    .61 bar

# 1985 BOMBARDIER CHALLENGER 601-1A | SN 3046



### OUTSIDE DIMENSIONS

Overall length	68 ft 6 in	20.90 m
Overall height	20 ft 9 in	6.3 m
Wingspan	64 ft 5 in	19.6 m

### CABIN DIMENSIONS

Length (excluding cockpit)	219 in	8.6 m
Height	73 in	1.9 m
Width	98 in	2.5 m

### Design Weights and Capacities

Max ramp weight	43,250 lb	19,618 kg
Max takeoff weight	43,100 lb	19,550 kg
Max landing weight	36,000 lb	16,330 kg
Max zero fuel weight	29,500 lb	13,381 kg
Max fuel capacity (6.7 lb / gal)	16,420 lb	7,448 kg
Payload with full fuel	930 lb	422 kg

### ENGINES

Two (2) General Electric CF34-3A		
Takeoff thrust	8,729 lb	38.83 kN
Bypass ration	6.2:1	

## 1985 BOMBARDIER CHALLENGER 601-1A | SN 3046

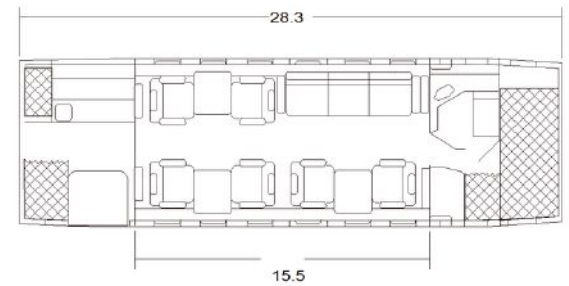
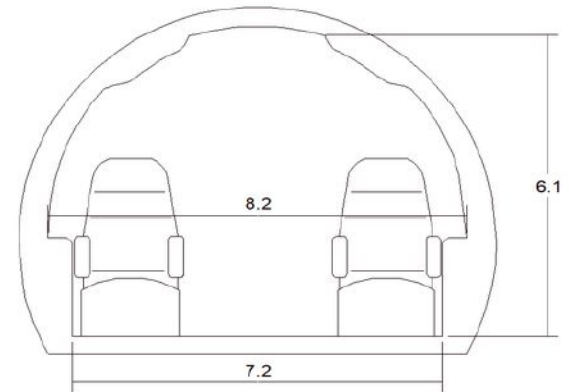
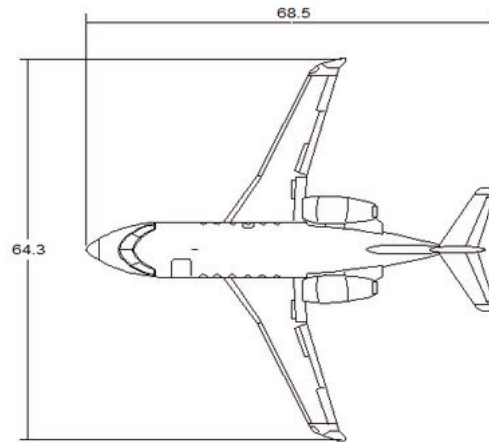
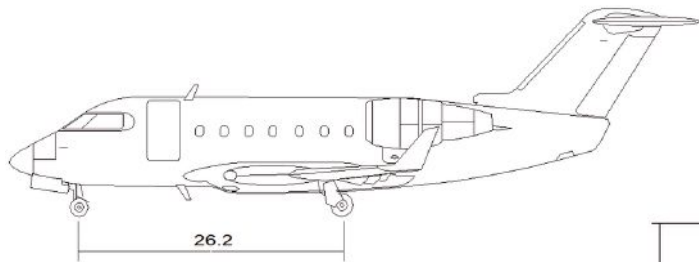



## 1985 BOMBARDIER CHALLENGER 601-1A | SN 3046



1985 BOMBARDIER CHALLENGER 601-1A | SN 3046





1985 BOMBARDIER CHALLENGER 601-1A | SN 3046



1985 BOMBARDIER CHALLENGER 601-1A | SN 3046





## 1985 BOMBARDIER CHALLENGER 601-1A | SN 3046



## 1985 BOMBARDIER CHALLENGER 601-1A | SN 3046





## 1985 BOMBARDIER CHALLENGER 601-1A | SN 3046



## 1985 BOMBARDIER CHALLENGER 601-1A | SN 3046



### **SOLJETS: YOUR TRUSTED PARTNER**

#### **EXPERIENCE, KNOWLEDGE, PASSION**

Whether you have a precise requirement for a specific aircraft, or a vague concept and understanding of your needs, the SOLJETS professionals have refined a SOLution that ensures YOUR needs, missions, and goals are met. With clarity we work together to provide the Intel and resources to enable YOU to make the best decisions – whether buying or selling. The SOLJETS SOLution has four key steps: Assess, Assemble, Act, Alliance.

#### **SOLJETS' FOCUS IS YOU**

The SOLJETS SOLution™ combines the ideal aircraft with the right process, ownership structure, and foundation to make sure that your jet is a simple, efficient, and satisfying part of your life. Freedom, adventure, time. With SOLJETS, that dream can become a reality.

#### **LEVERAGING ART & SCIENCE**

Matching the right aircraft with the right owner takes more than internet advertising and email campaigns. The team at SOLJETS leverages industry relationships built over decades of experience to broaden our global reach and uncover unique opportunities for you. Any buyer or seller can look through online ads to find a few retail solutions. At SOLJETS, our team goes where others won't to find the right buyer or seller. We've built deep ties with manufacturers, lenders, insurers, and global operators so that we are in a position to not only hear about transaction opportunities before others, but to be instrumental in making those opportunities work for you.